

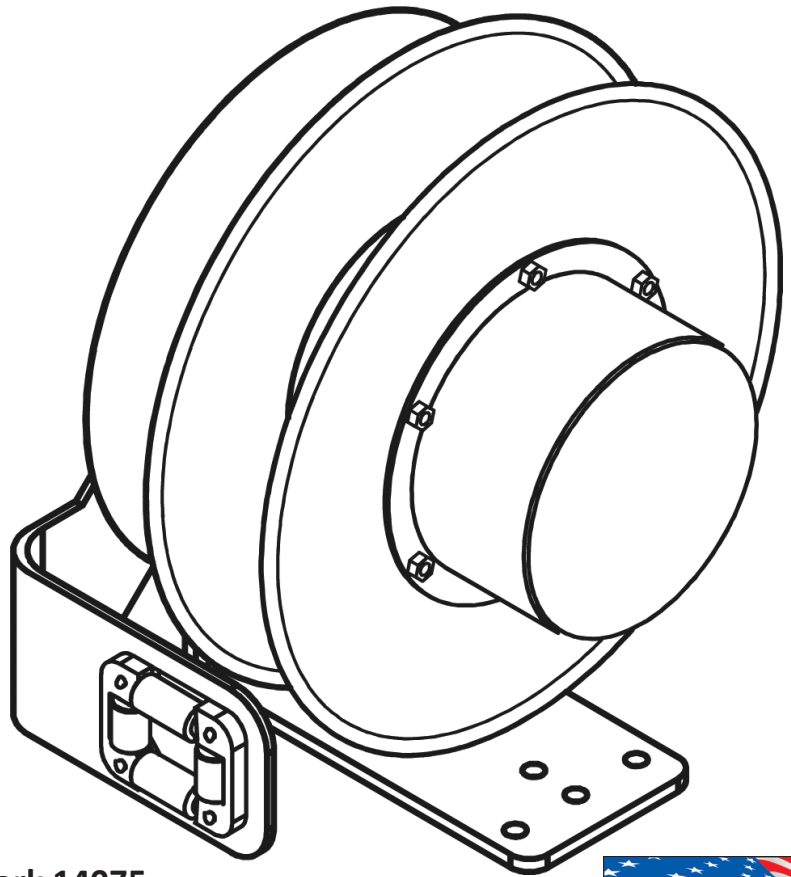

# ReelTuff™ RTI/RTM Series Spring Cable Reel Manual

Includes all models beginning in KH's ORI, ORM, RTI and RTM  
Retractable Power Cord Reel Series



160 Elmview Avenue, Hamburg, New York 14075

Phone: 716-312-0088 - Fax: 716-312-0028  
[www.khindustries.com](http://www.khindustries.com) - [info@khindustries.com](mailto:info@khindustries.com)



# KH Industries - Terms and Conditions of Sale

1. **TERMS AND CONDITIONS OF CONTRACT.** Except where otherwise provided in a written agreement duly executed by an authorized signatory of KH Industries, Inc. ("KH"), all goods and services supplied by KH pursuant to the Confirmation of Order overleaf and these terms and conditions (the "Goods") are provided subject to the details set out in the said Confirmation of Order and to the terms and conditions set forth herein. KH's ACCEPTANCE OF AN ORDER IS EXPRESSLY CONDITIONED UPON BUYER'S ASSENT TO THESE TERMS AND CONDITIONS, AND BUYER'S ACCEPTANCE OF GOODS HEREUNDER SHALL BE DEEMED AN ACCEPTANCE OF THESE TERMS AND CONDITIONS. KH specifically rejects any terms and conditions in Buyer's order or in any other document from Buyer that in any way conflict with, reduce or affect these terms and conditions.

2. **PRICES.** Unless otherwise agreed in writing, all prices are quoted F.O.B. at KH's premises in Hamburg, New York, USA. All price quotes by KH will remain valid for thirty (30) days. Thereafter, prices are subject to change without notice to Buyer. Typographic, clerical and manifest errors in any offer are subject to correction by KH at any time. The minimum billing per order is \$100 plus freight charges, orders that do not meet this minimum will be subject to a \$25 service charge.

3. **PAYMENT TERMS.** Payment for all Goods shall be made prior to shipment (either by cash, banker's draft, cashier's check, check drawn on good funds, telegraphic transfer or approved credit card) or, at the sole discretion of KH, C.O.D., unless Buyer has applied for and been granted a line of credit by KH, in which case purchases can be made up to approved credit limits with payment therefore due net 30 days. Late payments shall be charged interest at the rate of 1.5% per month. KH is entitled hereunder to delay shipment until payment monies have cleared (e.g. check has become final; credit card charge has been authorized). Credit terms are subject to change or withdrawal at any time at KH's sole discretion, regardless of prior credit arrangements. KH reserves the right to require current financial information from any buyer with an open account as a condition of the continued extension of credit. Buyer shall promptly reimburse KH in respect of KH's costs, including reasonable attorneys' fees, incurred in the collection of any monies owed to KH by Buyer. For orders invoiced or shipped outside the United States, KH will require a confirmed, irrevocable letter of credit, payable at sight in United States funds, advised and payable on an acceptable US bank. Buyer shall be solely responsible for procuring any and all necessary export, import and/or other permits. Buyer's order shall constitute a representation that Buyer is solvent, and KH is relying upon such representation. If KH at any time reasonably believes that the Buyer is insolvent or that the Buyer's credit is impaired, Buyer shall be in material breach thereof and hereof and KH may, without liability to Buyer, withhold performance hereunder, change the payment terms and/or repossess Goods delivered.

4. **ADDITIONAL COSTS & TAXES.** All prices and quotations are exclusive of sales, use, excise, duty, VAT and all similar taxes and levies. All such charges shall be for the account of Buyer and, if not included in an original invoice, may be invoiced or added to Buyer's credit card payment, if any, by KH at a later date.

5. **CHANGES; CANCELLATION OF ORDER.** If Buyer cancels or changes the order, or any part thereof, for any reason, Buyer agrees to pay cancellation charges for all costs incurred by KH due to such cancellation, including without limitation, costs incurred by KH in the design, development or manufacture of special, custom-made or custom-designed Goods, or goods altered at the request of Buyer, [plus related profit.] The costs shall include commitments made by KH to third parties for labor or materials for use in completing such order. KH's determination of cancellation charges shall be final and conclusive.

6. **SHIPPING.** Title in Goods and risk of loss or damage thereto shall pass to Buyer upon delivery thereof by KH to the carrier at FOB point. Goods shall be shipped in accordance with the information set out in the Confirmation of Order overleaf. Unless instructed otherwise by Buyer, KH may ship by any reasonable manner and routing. All shipping costs shall be for the account of Buyer. All shipments shall be insured for

their full replacement value and all such insurance shall be for the account of Buyer. [All orders are subject to KH's current shipping and handling charges.] KH shall not be liable or otherwise responsible for defaults or delays in delivery by carrier. Shipping dates set out on the Confirmation of Order are approximations only, subject to, inter alia, factory schedules and inventory. If any shipment of Goods is delayed due to any act or omission of Buyer, KH may charge Buyer reasonable storage fees in relation thereto, including without limitation, storage costs, insurance costs and cost of money. Unless otherwise agreed by KH in writing, KH, in its sole discretion, may make partial shipments of any order, for which pro rata payments shall be due and payable as indicated on the invoice issued pursuant thereto. KH reserves the right not to ship to Buyer if Buyer's account is overdue.

7. **ACCEPTANCE OF GOODS.** Buyer acknowledges that it has a duty to inspect Goods immediately upon receipt. Goods will be deemed accepted by Buyer unless notice of lawful rejection has been delivered in writing to KH within ten (10) business days after receipt thereof. Any notice of shortage must be delivered in writing to KH within three (3) business days after receipt thereof by Buyer. Any notice of damage to Goods must be delivered in writing to KH and the relevant carrier within three (3) business days after receipt thereof by Buyer. Authorization from KH must be received by Buyer in writing prior to the return of any Goods by Buyer hereunder, and Buyer shall be solely responsible for adequate packing and pre-payment of freight with respect thereto. For the avoidance of doubt, KH shall not be obligated to accept any unauthorized return of Goods, any Goods inadequately packed or Goods for which freight has not been fully pre-paid by Buyer.

8. **RETURNED GOODS.** KH may, at its sole option, agree to accept unused and merchantable Goods from Buyer, subject always to a re-stocking charge of 20%. Buyer agrees that it shall not return any Goods prior to receiving written authorization from KH so to do. Any and all returned Goods shall be shipped freight pre-paid and risk of damage or loss shall remain vested in Buyer until the relevant Goods are received, inspected and accepted by KH. For the avoidance of doubt, KH is not obligated to accept any returned Goods pursuant to this paragraph. Custom manufactured Goods are non-cancelable/non-returnable.

9. **RE-CONDITION & REPAIR.** Before shipping any Goods to KH for such repair, Buyer shall contact KH for Return Merchandise Authorization (RMA), and shipping instructions. With respect to any repairs by KH, Buyer shall be solely responsible for payment of freight charges, replacement parts, and labor costs at KH's then current prices. Any repairs to any of the Goods performed by Buyer or by third parties [pre-approved by KH] shall be carried out in strict accordance with the applicable repair manual(s), if any, published by KH from time to time.

10. **LIMITED WARRANTY; EXCLUSION OF OTHER WARRANTIES; LIMITATION OF REMEDIES; INDEMNITY.**

KH warrants the Goods to be free from defects of materials or workmanship, under normal and proper use and service, for a warranty period of one (1) year from the date of shipment. If any of the Goods proves to be defective in material or workmanship within said warranty period, such Good(s) shall be promptly returned to KH, shipping charges prepaid, and if the same is determined by KH to be defective in material or workmanship, it will be replaced or repaired, at the exclusive election of KH, free of charge, F.O.B. KH's factory. If Buyer discovers that the Goods, or any of them, do not conform to the warranty specified hereinabove, Buyer shall immediately [cease using such Good(s) and] notify Seller in writing of such non-conformity, specifying in reasonable detail the nature thereof.

THIS WARRANTY IS MADE AND ACCEPTED IN LIEU OF ALL OTHER WARRANTIES, EXPRESS OR IMPLIED, WHETHER OF MERCHANTABILITY OR OF FITNESS FOR A PARTICULAR PURPOSE OR OTHERWISE, AS BUYER'S EXCLUSIVE REMEDY FOR ANY DEFECTS IN THE GOODS, AND ALL OTHER REMEDIES ARE EXPRESSLY DISCLAIMED.

No warranty is made by Seller for consumables or for normal wear and tear, or for Goods which have been set up, operated and/or installed other than in strict accordance with KH's

written instructions; or which have been subjected to improper installation, misuse, negligence or accident; or which have been serviced, repaired or altered improperly or by anyone other than Seller [or Buyer or third party approved by Seller, in strict accordance with the applicable repair manual(s), if any, published by KH from time to time]; or which have been used in a manner or for a purpose for which the Goods were not designed. No warranty is made with respect to any defects in the Goods due to plans or instructions supplied to Seller by or for Buyer. All other obligations and liabilities of Seller, whether directly or by way of indemnity, for special, incidental, consequential or other damages, whether based on breach of contract, warranty, tort (including negligence), strict products liability, patent or trademark infringement, or any other theory in connection with the purchase or use of the Goods, are expressly EXCLUDED. In no event will Seller be liable on any claim that Goods are defective for an amount in excess of the price paid by Buyer for the Goods. Buyer hereby expressly assumes all risk as to the suitability, performance quality and compatibility of the Goods, and in this respect the product is being provided on an "AS IS" basis. [Buyer acknowledges that some of the Goods might be used in inherently dangerous activities and, accordingly, expressly bears the risk of injury, damages and other harm to itself and to third parties arising out of use of any of the Goods in such inherently dangerous activity(ies). Furthermore, Buyer agrees to indemnify, hold harmless and keep indemnified KH for any claims, awards, damages or other costs incurred by KH, including reasonable attorneys' fees, arising out of the use of any Good(s) in inherently dangerous activities.] While KH uses reasonable endeavors to ensure the accuracy and quality of its publications, sales literature and other printed materials, from time to time errors might occur in that regard. KH therefore does not guarantee the accuracy or completeness of any publication or other informational materials.

11. **INTELLECTUAL PROPERTY.** The purchase by Buyer of any Goods hereunder does not grant to, convey or confer upon Buyer or Buyer's customers, or upon anyone claiming under Buyer, a license or any other legal interest, express or implied, under any patent right, trademark, copyright or other intellectual property right, whether registered or not and whether pending or not, in any jurisdiction, of KH covering or relating to any of the Goods or any combination or process in which any of the Goods might be or are used.

Buyer understands and agrees that KH does not warrant that the Goods are free of claims of patent, trademark, trade secret or copyright infringement by a third party. KH hereby disclaims any such warranties or indemnification for such infringement(s) or intellectual property rights.

Any rights not expressly granted herein are reserved by KH.

12. **FORCE MAJEURE.** KH shall not be liable for any failure to perform under the Confirmation of Order or these terms and conditions if it is unable to obtain parts or supplies at reasonable prices or through usual and regular sources on a timely basis, or due to any interruption of transportation, government regulation, labor disputes, strikes, riots, war, civil commotion, fire, flood, accident, storm, or act of God, or other cause beyond KH's reasonable control that renders it impractical for KH to perform.

13. **GENERAL.** This Agreement will be governed by and construed in accordance with the laws of the State of New York. The application of the United Nations Convention for the International Sale of Goods, if it would otherwise apply, is hereby expressly excluded. These terms and conditions and the Confirmation of Order overleaf set out the entire agreement between KH and Buyer relating to the Goods and supersede any prior agreement, arrangement, purchase order, correspondence, communication, advertising or representation concerning the Goods. This Agreement may not be modified or amended except by a written instrument duly executed by authorized signatories of the parties. If any provision of this Agreement is held to be invalid or unenforceable, that provision is to be given effect to the maximum extent permissible and the remaining provisions of this Agreement will remain in full force and effect. Notices hereunder shall be delivered in writing by registered mail to the addresses of the parties overleaf, or as notified to the other party from time to time.

## 1.0 Safety

- 1.1 Electrical Warnings
- 1.2 Operational Warnings
- 1.3 Maintenance Warnings
- 1.4 Specifications and Listings
- 1.5 Electrical Rating
- 1.6 Labels and Marking

## 2.0 Installation

- 2.1 Application Types
- 2.2 Mounting
- 2.3 Guide Rails
- 2.4 Roller Guides
- 2.5 Ratchet
- 2.6 Spool Lock
- 2.7 Cable Installation and Replacement
- 2.8 Slip Ring Replacement
- 2.9 Electrical Connections
- 2.10 Spring Tension Adjustment

## 3.0 Operation

## 4.0 Maintenance

- 4.1 Maintenance Warnings
- 4.2 Lubrication
- 4.3 Inspections
- 4.4 Spring Motor Replacement

## 5.0 Troubleshooting

### RECORD

The catalog number of the reel and the serial number of the reel are required when ordering replacement parts or discussing the reel with the factory. Please record this information now in the spaces provided below.

CATALOG NO. OF REEL \_\_\_\_\_

SERIAL NO. \_\_\_\_\_

DATE INSTALLED \_\_\_\_\_

# Basic Component Identification

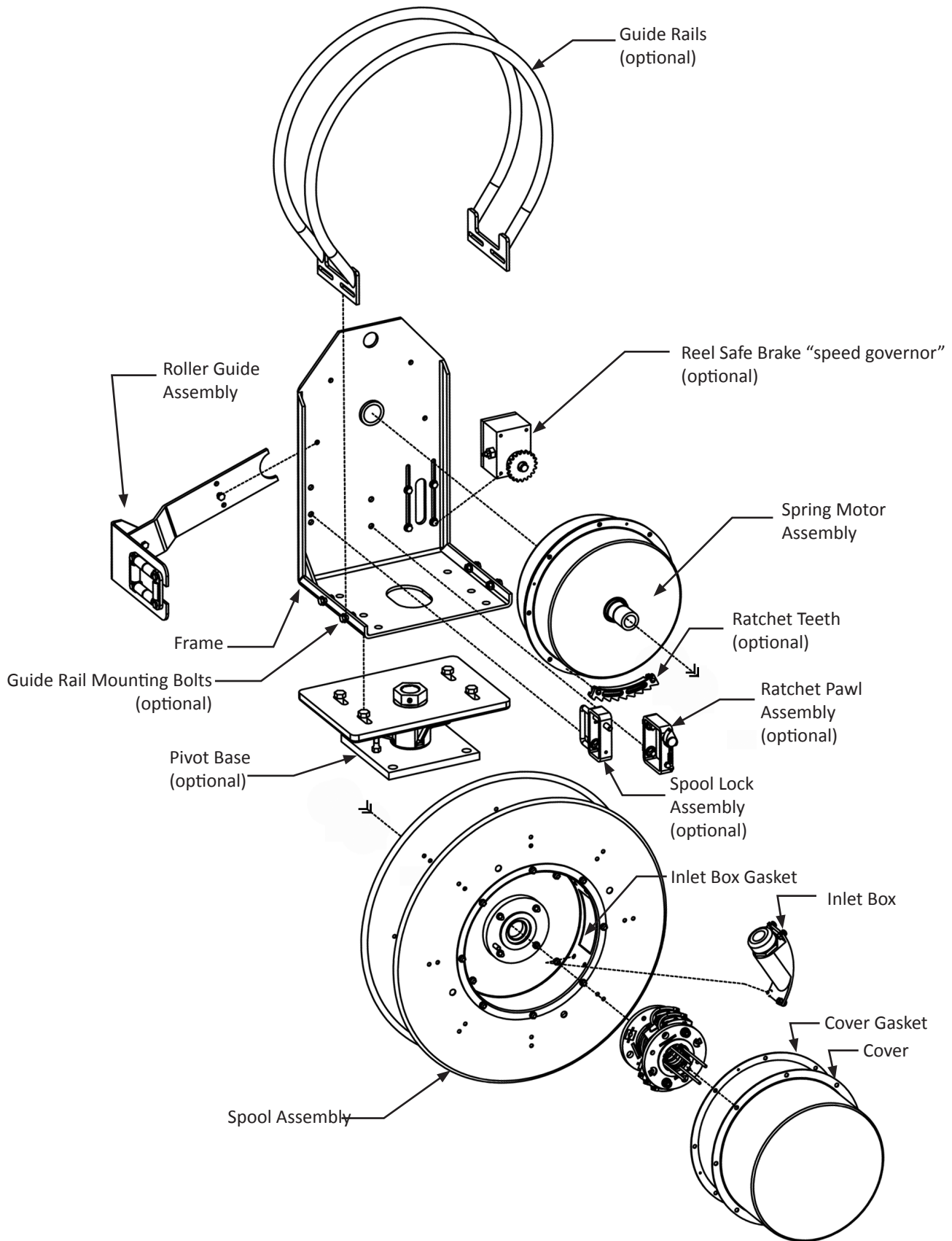

## 1.1 Electrical Warnings

1.1.1 This equipment should be properly grounded before use, in accordance with both the National Electric Code and local codes and ordinances.

1.1.2 The electrical power should be disconnected from the cable reel before any service functions are performed.

1.1.3 This cable reel must not be used for loads greater than the voltage and current rating of the cable. The ampacity rating of the cable reel shall be in accordance with the National Electric Code.

## 1.2 Operational Warnings

1.2.1 Exercise care when handling the cable reel during normal operation. This cable reel has a rotating spool powered by springs under tension.

1.2.3 Do not use cable different from that for which the reel is intended. Changes in diameter, weight per foot, length of cable or flexibility will affect the operation of the reel.

1.2.4 Mounting hardware and fasteners should be installed to maintain tightness under vibration and checked periodically to assure tightness.

1.2.4.1 Overhead installation mountings should be such that the reel is not supported by bolts in tension. A safety chain or cable is strongly recommended to minimize damage and/or possible injury in the event of mounting failure.

## 1.3 Maintenance Warnings

1.3.1 **WARNING:** Modification of this equipment may cause excessive wear and will void the warranty. Contact the manufacturer regarding changes or modifications of equipment which could affect reliability or safety.

1.3.2 **DO NOT DISASSEMBLE THE SPRING MOTOR FOR ANY REASON.** Serious personal injury could result. This cable reel is equipped with springs under tension. Contact the factory for assistance.

**Call: 1-716-312-0088**

## 1.4 Specifications & Listings

1.4.1 The following specifications apply to standard RTI and RTM Series Cable PowerReels:

1.4.1.1 RTI and RTM Series Cable Reels are intended for commercial / industrial use and are provided with a permanent mounting base.

1.4.1.2 RTI and RTM Series Cable Reels are built to NEMA 4 Specifications and are suitable for indoor/outdoor use.

1.4.1.3 Spring Motors for the RTI and RTM Series are sealed for safety and weather-tight for long-life.

1.4.1.4 Ampere capacity of the RTI and RTM Series Reels range from 10 to 150 Amperes and from 250 to 600 Volt maximum. Reels are available in 3 to 30 conductor configuration

1.4.1.5 RTI and RTM Series Cable Reels are available with optional features which increase safety, enhance performance, and improve serviceability. Options include: ratchet, pivot base, spool lock, junction box, and guide rails.

1.4.1.6 Custom power and signal circuit slip rings using silver plated slip rings and silver graphite brushes are available on request.

## 1.5 Electrical Rating

### 1.5.1 Reels not equipped with cable:

1.5.1.1 Reels not equipped with flexible cable are rated in Amperes and volts. Consult Table 1.6 for appropriate cable/conductor combinations.

1.5.1.2 The amp and voltage rating of the cable should not be greater than the slip ring circuit. See Slip Ring Replacement Chart on page 18. Consult Table 1.6 for appropriate cable/conductor combinations.

### 1.5.2 Reels Equipped with Cable:

1.5.2.1 Reels equipped with flexible cable should not be used at voltages and/or amperages above the rating of the reel or the cable.

## 1.6 Labels & Marking

1.6.1 Every cable reel is marked with a label on the frame which includes the KH Industries name and logo, the product catalog number and the individual product serial number.

### 1.6.2 Reels equipped with cable:

1.6.2.1 The marking on reels equipped with a flexible cable shall include the current and voltage ratings.

### 1.6.3 Reels not equipped with cable:

1.6.3.1 The rating of a reel not equipped with cable is completed upon installation of cable and is determined by the installed cable, wire size and number of conductors, and is not to exceed the indicated maximum rating of the slip ring.

(See Table 1.6 below). The marking shall include the following:

- \* The type (SOW, W, G-GC, etc.),
- \* The AWG cable size,
- \* The maximum length of cable with which the reel is intended for use.

1.6.3.2 The maximum amperage and voltage rating for cable reels supplied without cable is on the KH Industries Identification label.

1.6.3.3 The cable reel is designed to handle cable with a temperature rating of up to 90° C, which is marked on the cable.

**Table 1.6**  
**Allowable Ampacities for Flexible Cord & Cable**

Type G-GC(90°C)		Type W (90°C)		Type SOW-A, SOOW-A (90° C)				Color Code Chart		
Cable	Ampacity	Cable	Ampacity	Cable	Ampacity	Cable	Ampacity	Cond. No.	Base Color	Tracer Color
8/3 G-GC	50	W 8/2	50	16/2	13	12/2	20	1	Green	-
6/3 G-GC	65	W 8/3	50	16/3	10	12/3	20	2	Black	-
4/3 G-GC	85	W 8/4	45	16/4	8	12/4	16	3	White	-
2/3 G-GC	115	W 6/2	65	16/5	8	12/5	16	4	Red	-
		W 6/3	65	16/6	8	12/6	16	5	Orange	-
		W 6/4	55	16/7	7	12/7	14	6	Blue	-
		W 4/2	90	16/8	7	12/8	14	7	White	Black
		W 4/3	85	16/10	7	12/10	14	8	Red	Black
		W 4/4	75	16/12	7	12/12	14	9	Green	Black
		W 2/2	120	16/14	7	12/14	14	10	Orange	Black
		W 2/3	115	16/16	7	12/16	14	11	Blue Black	Black
		W 2/4	100	16/20	7	12/20	14	12	Black	White
		W 1/2	140	16/24	6	12/24	14	13	Red	White
				16/30	6	12/30	12	14	Green	White
				14/2	15	10/2	25	15	Blue	White
				14/3	15	10/3	25	16	Black	Red
				14/4	12	10/4	20	17	White	Red
				14/5	12	10/5	20	18	Orange	Red
				14/6	12	10/6	20	19	Blue	Red
				14/7	10.5	10/7	17.5	20	Red	Green
				14/8	10.5	10/8	17.5	21	Orange	Green
				14/10	10.5	10/10	17.5	22	Black	-
				14/12	10.5	10/12	17.5	23	White	-
				14/14	10.5	10/14	17.5	24	Red	-
				14/16	10.5	10/16	17.5	25	Green	-
				14/20	10.5	10/20	17.5	26	Orange	-
				14/24	10.5	-	-	27	Blue	-
				14/30	9	-	-	28	White	Black
								29	Red	Black
								30	Green	Black

## 2.1 Application Types

### 2.1.1 Stretch Applications



2.1.1.1 The cable is suspended without any intermediate support. Stretch reels generally require a line pull equal to two times the weight of the cable, which allows approximately 10% sag at full extension. On long applications where sag cannot be tolerated, it is sometimes desirable to put supports at intervals of 5 to 10 feet.

### 2.1.3 Drag Applications

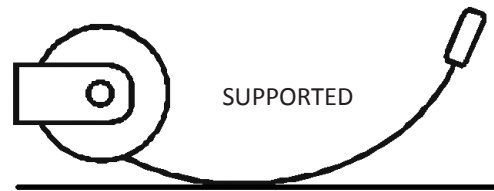

2.1.3.1 The reel is mounted on a stationary object and is required to drag the cable over the surface to the reel. The cable is supported by the ground or some type of cable tray. A ball stop may be required.

### 2.1.4 Retrieve Applications

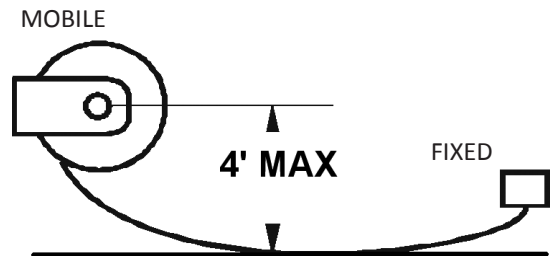

2.1.4.1 The reel is mounted on the moving object and winds up or pays out the cable as the machine approaches or moves away from the fixed end. Retrieve applications can be elevated 4 feet from the cable support surface.

### 2.1.2 Lift Applications

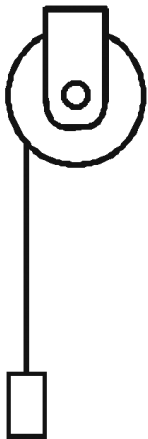

2.1.2.1 The cable is lifted vertically in lift applications. The reel is normally designed to handle only the total weight of the cable. Some lift applications may require a ball stop and ratchet to control the length of cable to be retracted.

## 2.2 Mounting

### 2.2.1 Standard Mounting

2.2.1.1 Mount the base of the reel to any flat surface which is structurally sound enough to support the reel and the forces of winding and unwinding the cable.

2.2.1.2 The spool drum must be mounted horizontally.

2.2.1.3 The cable should extend perpendicular to the rotation of the spool. The total cable deflection should not exceed 15° to either side of the centerline of the spool.

2.2.1.4 If deflection is constant to either side of the reel and operation is impaired, re-mount the reel.

2.2.1.5 If the angle of deflection exceeds 30°, a Pivot Base or two way payout guide should be used, otherwise excessive cable wear and unreliable operation will result.

2.2.1.6 A safety chain is recommended for all overhead installations. Attach the safety chain using the 0.39" hole provided in the base.

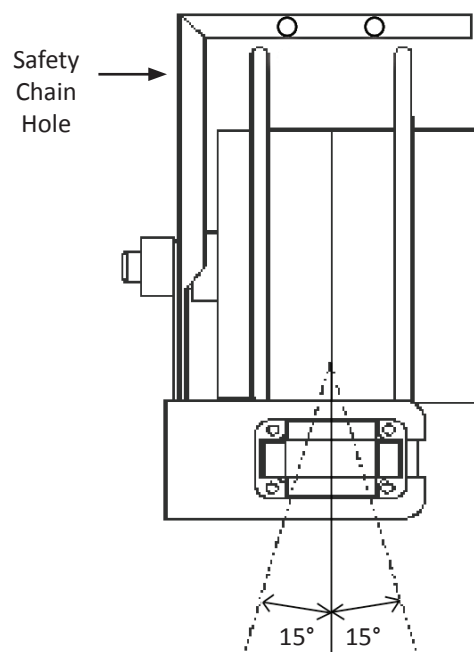

## 2.0 Installation

### 2.2.2 Pivot Base Mounting

2.2.2.1 All RTI and RTM Series Cable Reels can be furnished with a pivot base to allow the reel to rotate and keep the extended cable perpendicular to the application.

2.2.2.2 Pivot Bases rotate up to 345°. If 360° rotation is required contact the factory.

2.2.2.3 A pivot base is required in carousel or loop-track applications.

2.2.2.4 When a pivot base is used the reel must be mounted horizontally ("ceiling" or "floor" mounted).

2.2.2.5 The Roller Guide should be mounted to require the cable to travel perpendicular to the axis of pivot base rotation. This will guard against cable twisting and ensure effective swivel action from the pivot base.

2.2.2.6 Mount Pivot Base in the position that best centers the spool over the pivot axis.

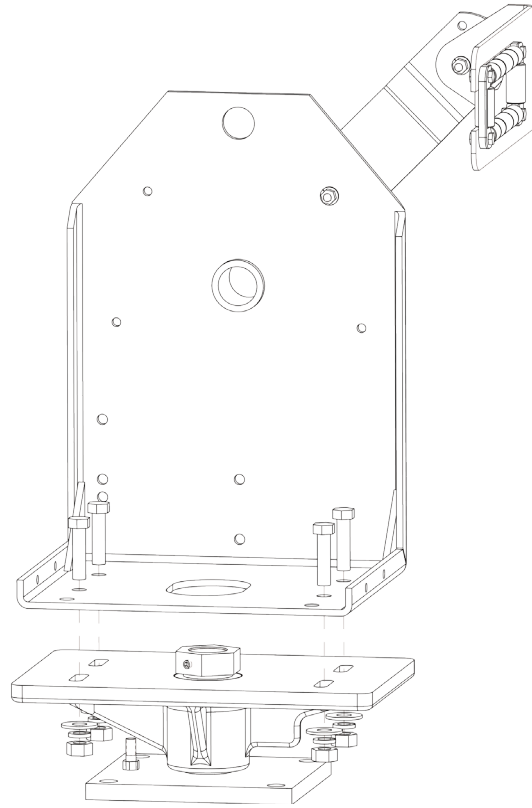

### 2.3 Guide Rails

2.3.1 The optional guide rails can be installed on any of the RTI and RTM Series Cable Reels.

2.3.2 Guide Rails provide a barrier between the cable and the rotating spool flange rim. They also act as a safety barrier for installations where human contact with the rotating spool flange is likely to occur.

2.3.3 Guide Rails provide additional assurance that the cable will wrap efficiently on the spool for applications involving rigorous motion.

2.3.4 Guide Rails can act as a substitute for the roller guide in applications that require a two-way pay-out.

#### 2.3.5 Guide Rail Installation

2.3.5.1 Guide Rails are mounted to the base using the same bolts that mount the reel. Note: Later versions may have guide rail mounted on sides of base.

2.3.5.2 Mount Rails as shown.

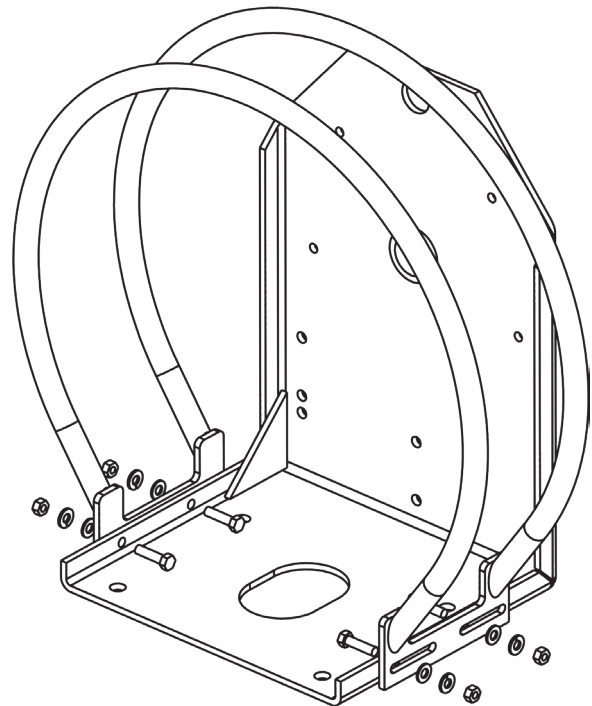

### 2.4 Roller Guides

2.4.1 All RTI and RTM Series Cable Reels are equipped with an adjustable roller guide. The guide's function is to center the cable on the spool and to help the reel wrap cable more evenly.

2.4.2 Level winding is inhibited by the cable bearing against either of the spool flanges during operation. The Roller Guide helps to alleviate this condition.

2.4.3 The guide consists of two elements: the guide arm and the guide head. The guide must be adjusted and secured prior to terminating any electrical connections.

2.4.4 The guide should be secured at the position that causes the least change of cable direction to occur at the guide; otherwise, cable life will be reduced.

2.4.4.1 Mount the guide arm to the base by positioning the open end of the arm against the groove between the shaft coupling and the frame. Secure the guide arm using the provided 5/16-18 hex head cap screw, spring-type lock washer, and 5/16-18 hex nut. There are four holes in the frame and three holes in the arm to provide a total of 12 possible mounting positions.

2.4.4.2 The guide head may be adjusted freely through 60° degrees for applications that require precise alignment.

2.4.4.3 Attach the guide head to the end of the guide arm using the provided hardware.

2.4.5 Cable can be released for maintenance by removing the rollers on the Guide Head without disconnecting the cable.

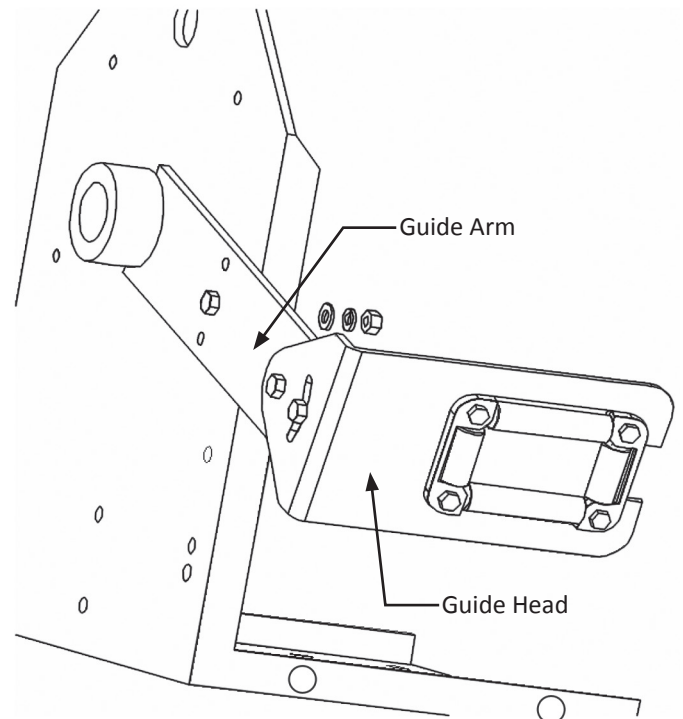

### 2.5 Ratchet

2.5.1 The ratchet option allows the extended cable to be pulled out and held from retraction by spring tension; generally appropriate for operator attended applications.

2.5.2 The ratchet for the RTI and RTM Series Cable Reels is spring loaded. It is designed to function in all acceptable mounting configurations.

2.5.3 The ratchet option can be installed at the time of purchase or later added or removed to/from reels that have already been introduced to service.

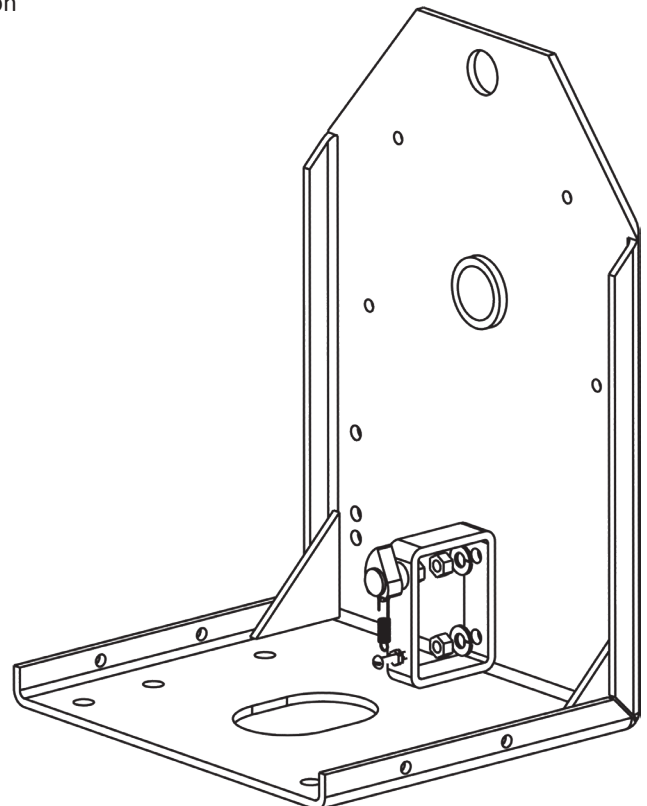

## 2.0 Installation

### 2.5.4 Ratchet Option Installation

2.5.4.1 **WARNING:** Power should be disconnected from the reel before beginning any service or maintenance functions. Follow lock-out/tag-out procedures appropriate to the installation.

#### 2.5.4.2 Ratchet Pawl Installation

2.5.4.2.1 The ratchet pawl assembly is attached to the reel frame as a unit. The holes provided for the attachment of The ratchet pawl assembly are located in the lower middle area of the frame.

2.5.4.2.2 Insert the two (2) provided 3/8-16x1" bolts in the frame.

2.5.4.2.3 Position the ratchet pawl assembly over the protruding bolt shafts.

2.5.4.2.4 Secure using the two (2) provided sets of 3/8-16 hex nuts & lock washers.

#### 2.5.4.3 Ratchet Plate Installation

2.5.4.3.1 The cable must be extended far enough to allow the removal of the two spring-side flange bolts that are aligned with the cable entrance. (See item A below).

2.5.4.3.2 Substitute the provided longer flange bolts and nuts for the removed bolts and nuts.

2.5.4.3.3 Position the ratchet plate over the bolts on the outside of the spring-side flange. When viewed from the frame, the square tooth of the ratchet plate should be to the left-hand side.

2.5.4.3.4 Secure the ratchet plate to the spool by tightening the nuts to approximately 7 (seven) ft-lbs.

2.5.4.3.5 Additional ratchet plates may be installed but will increase the likelihood of spool lock-up at full cable extension.

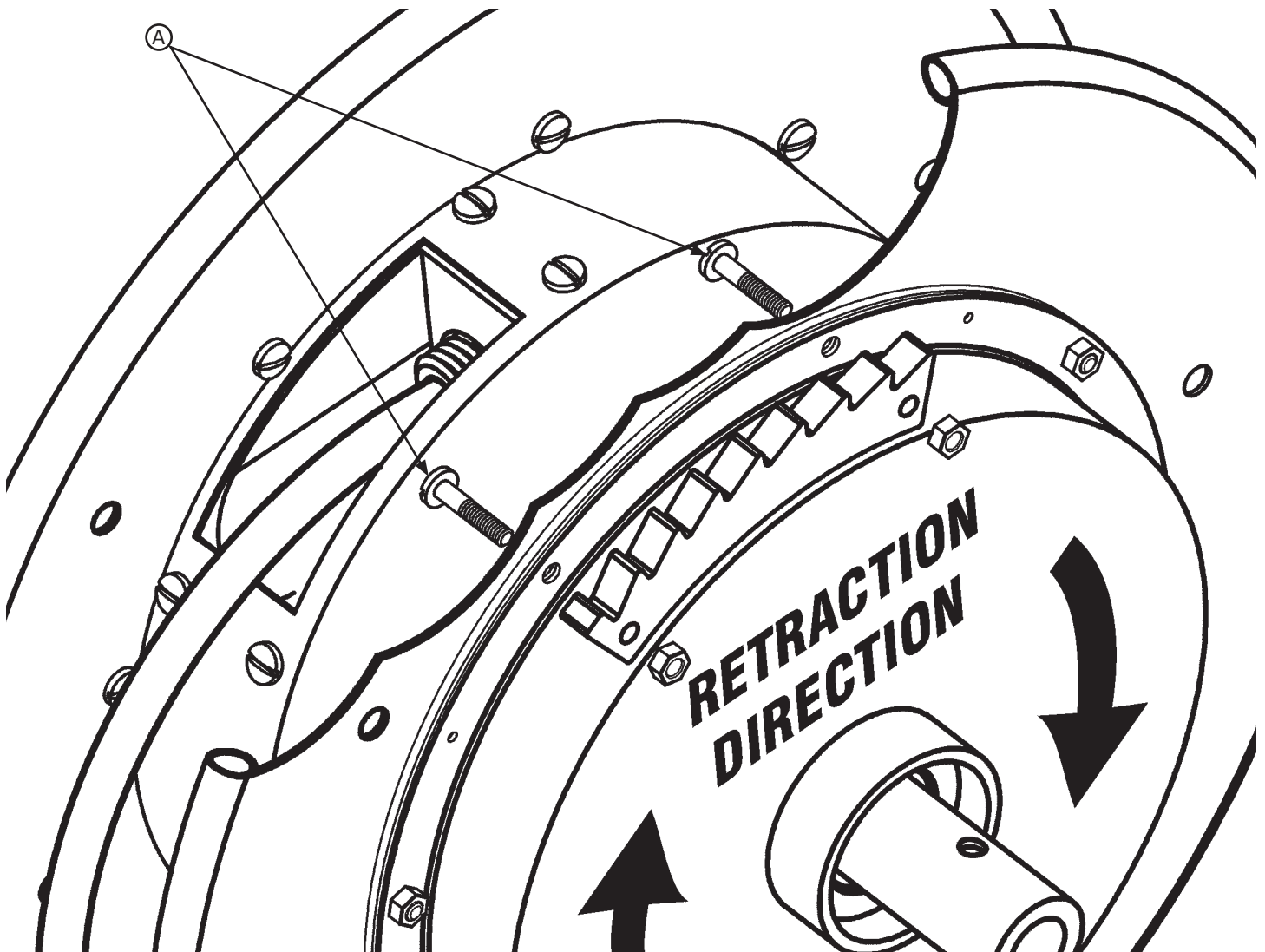

### 2.6 Spool Lock

2.6.1 All RTI and RTM Series Cable Reels can be equipped with an optional Spool Lock.

2.6.2 The Spool Lock allows the power spring tension to be locked out from the cable spool. Applications that often require cable replacement would benefit from the addition of the Spool Lock.

2.6.3 The spring-loaded design of the Spool Lock maintains engagement under conditions of shock & vibration. This is good for applications which require the cable to remain extended and are subject to severe service conditions.

#### 2.6.4 Spool Lock Installation

2.6.4.1 Attach the spool lock riser with (1) 3/8 x3/4 bolt finger tight.

2.6.4.2 Insert the lock into the hole in the frame and the first riser hole. Place the spring on the lock shaft before it goes through the second riser hole.

2.6.4.3 Hold the spring back and insert a roll pin to keep the spring in position. Use the provided insert tool to center the roll pin through the shaft.

2.6.4.4 Tighten the mounting bolt.

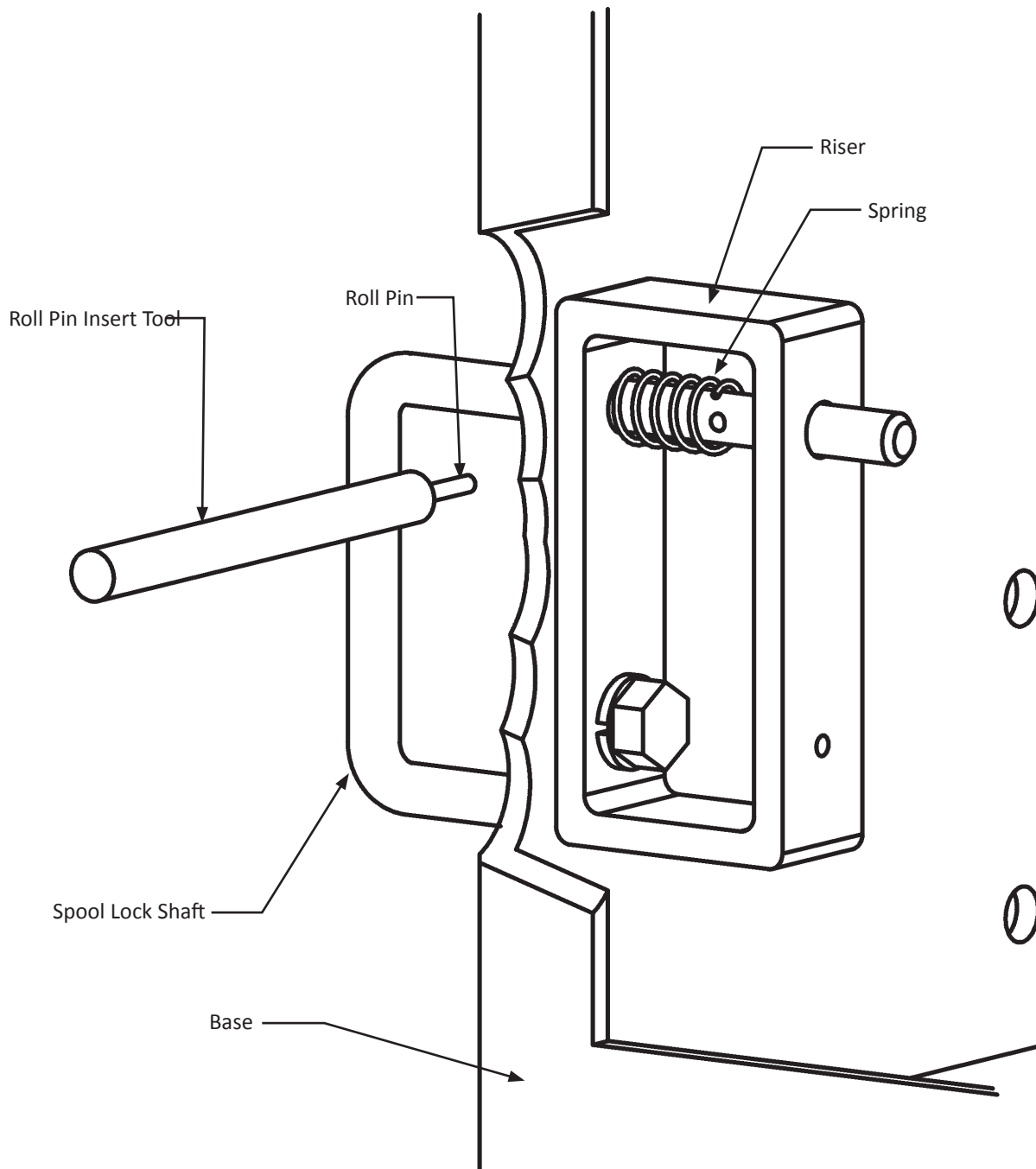

### 2.7 Cable Installation & Replacement

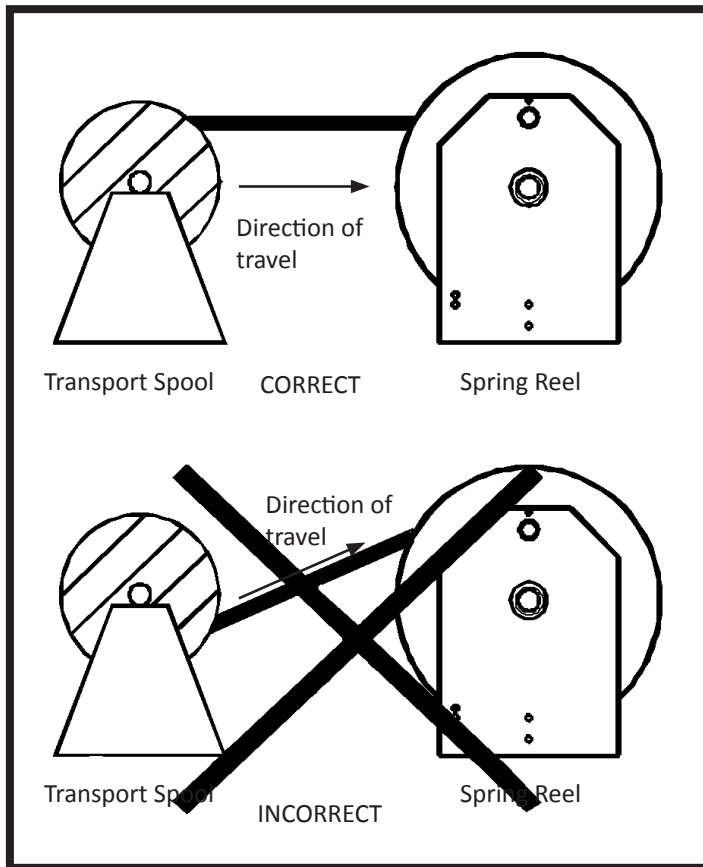

#### 2.7.1 Cable Removal

- 2.7.1.1 If an existing cable is being replaced you must first remove the old cable.
- 2.7.1.2 Disconnect all power as per Lock-Out/Tag-Out procedures as outlined in OSHA Section 1910.147.
- 2.7.1.3 Remove the Slip Ring Cover.
- 2.7.1.4 Mark existing cable connections .
- 2.7.1.5 Disconnect wires at the Slip Ring Brush Terminals.
- 2.7.1.6 Loosen the cable clamp and release the cable.
- 2.7.1.7 Loosen strain relief/watertight in the recessed Inlet Box on the spool.
- 2.7.1.8 Pull out and discard the old cable.

#### 2.7.2 Cable Installation

2.7.2.1 Prepare the cable to be loaded onto the reel. Support the cable as shown, or lay the full length of cable out in the direction of travel. Make sure the cable will lay flat by removing any twist from the cable. All weld cable lead ends should be tinned for optimal performance.

2.7.2.2 Insert the end of the cable to be connected to the slip ring through the guide arm and through the recessed inlet box on the spool. Pull enough cable through the inlet box and cable clamp to allow unstrained connections to the slip ring.

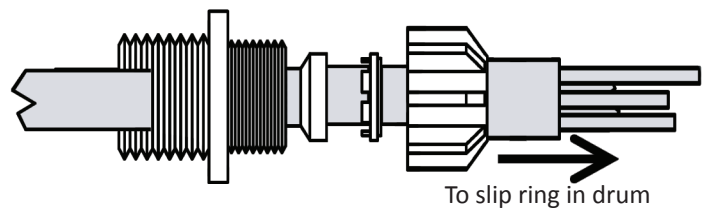

2.7.2.3 Unscrew the two parts of the strain relief/watertight and slide both sections and the neoprene grommet over the end of the cable as shown. Be sure to keep the fastening end last.

#### 2.7.3 Cable Connections

2.7.3.1 Connect the cable to the Slip Ring terminals. Verify that the cable leads do not interfere with the free running of the slip ring brushes. For additional information on wiring see Section 2.8, Slip Ring Installation & Replacement.

2.7.3.2 Secure the watertight connector. Jacketed cable should intrude 4-5 inches into the drum. Smaller watertights are secured using a Bridgeport sealing nut.

#### 2.7.4 Cable Loading

2.7.4.1 Wind the cable onto the spool by rotating the spool counterclockwise, as viewed from the slip ring cover.

2.7.4.2 Follow Spring Tensioning Procedure 2.10 to adjust the spring tension as required by the application.

2.7.4.3 Verify all connections before initiating or restoring electrical power to the cable reel.

2.7.4.4 Visually inspect both reel and cable after initial electrification.

## 2.8 Slip Ring Replacement

2.8.1 Disconnect and secure the electrical power as per Lock-Out/Tag-Out procedure outlined in OSHA 1910.147, Appendix A.

2.8.2 Remove the Slip Ring cover.

2.8.3 Disconnect the Spool Cable Connections from the Slip Ring Brush Terminals. Mark/Note the existing cable connections.

2.8.4 Disconnect the Slip Ring Core Leads from the Junction Box terminals or, if there is no Junction Box, cut the wire as close as possible to the crimp connector.

2.8.5 Loosen the two 1/4-20 Set Screws in the drive collar using a 1/8" Hex (Allen) Wrench.

2.8.6 Remove the Slip Ring from the end of the spool shaft.

2.8.7 After removing the Slip Ring use sand paper to remove the set screw burrs from the spool shaft. If the burrs are not removed the Slip Ring may not slide on the shaft.

2.8.8 Install the new Slip Ring on the shaft.

2.8.9 Be sure the hole in the Slip Ring Outboard Bearing closest to Brush #2 fits over the DrivePin. The Drive Pin must extend through the hole.

2.8.10 Secure Set Screws to 7 ft-lbs.

2.8.11 Connect the new Slip Ring to both the Spool Cable and Feeder Wire Connections.

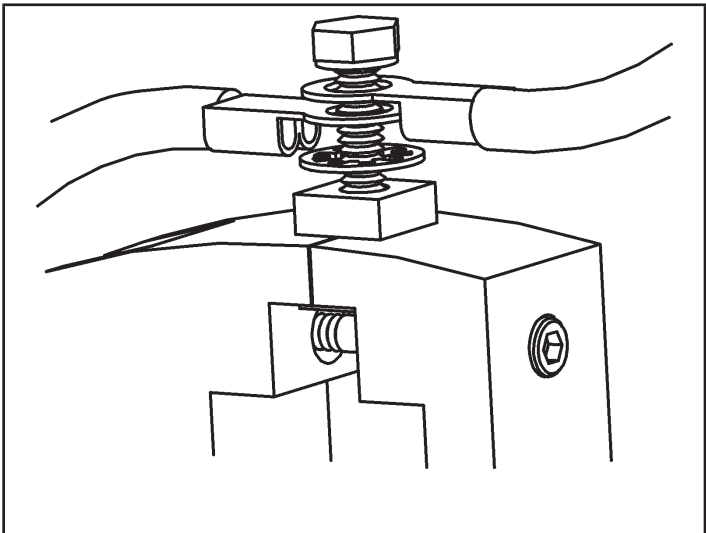
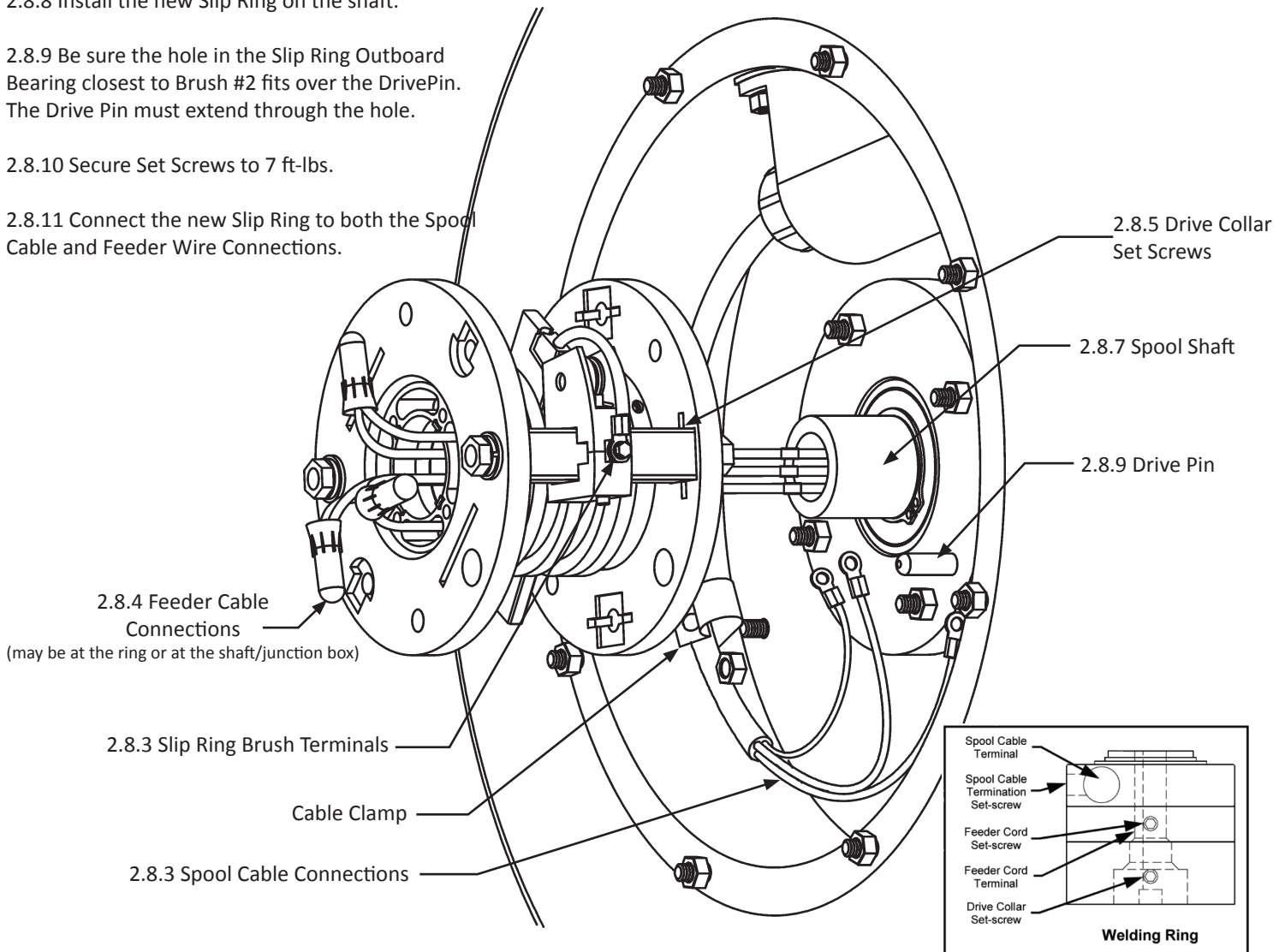

**CAUTION: INCORRECT CONNECTION OF LEAD TERMINALS WILL RESULT IN UNIT FAILURE.**

**NOTE: Keep Spool Cable Connections Clear of Slip Ring Brushes!**

## 2.0 Installation

### 2.9 Electrical Connections

#### 2.9.1 Electrical Warning

2.9.1.1 Electrical connections are determined by the requirements of the application and the configuration of the reel.

2.9.1.2 All electrical work should be performed by a qualified electrician.

2.9.1.3 Factory installed cable is wired with ring one (the ring closest to the drive collar) designated as ground, wired with the green cable conductor.

2.9.1.4 A continuity check should be performed prior to energizing the reel to verify electrical connections.

#### 2.9.2 Spool Cable Connections

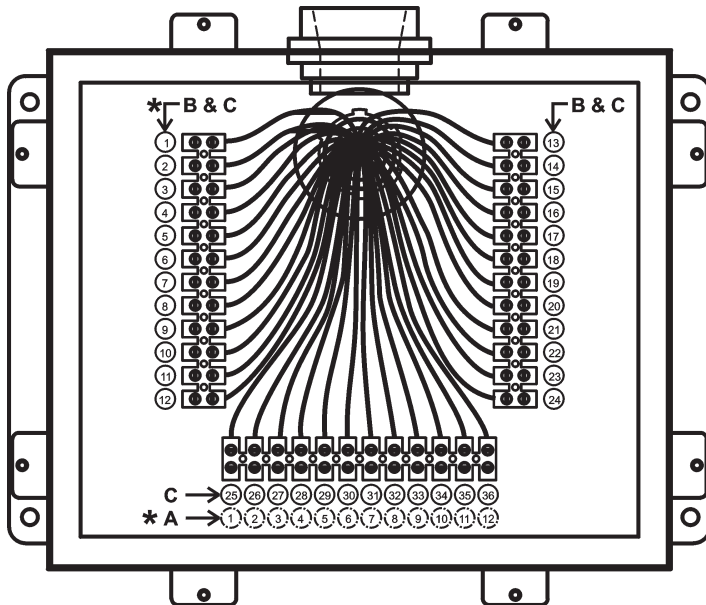

\* #1 DESIGNATED GROUND

2.9.2.1 See Section 2.7 for information on connecting the cable from the spool to the slip ring.

#### 2.9.3 Supply Cable Connections.

##### 2.9.3.1 Reels without Junction Boxes.

2.9.3.1.1 Standard RTI & RTM Cable Reels do not have junction boxes for electrical connections.

2.9.3.1.2 Reels without junction boxes are intended to have the supply cable attached by either conduit or water tight fitting installed into the 1" NPT internal threads at the end of the shaft.

2.9.3.1.3 The nylon bushing in the end of the shaft is there to protect the wire leads from the threads in the shaft during shipping. THE NYLON BUSHING MUST BE REMOVED DURING INSTALLATION OF THE REEL.

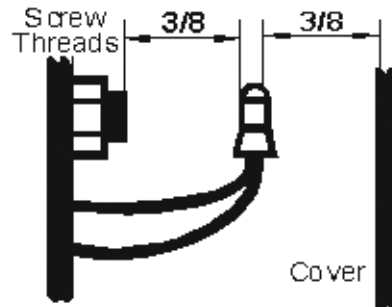

2.9.3.1.4 Supply cable connections are made either at the top of the slip ring or at the shaft entrance using crimp connections.

2.9.3.1.5 Connections made at the slip ring require adequate clearance. After making all connections, wire leads should be bent to clear both the brush post screw thread and the inside of the slip ring cover.

##### 2.9.3.2 Reels with Junction Boxes

2.9.3.2.1 NEMA 4 or 12 rated junction boxes are available for the RTI and RTM Series Cable Reels. Overall dimensions vary depending on AWG wire size and number of conductors and rating classification.

2.9.3.2.2 Junction Box Terminals are numbered from the top down, left to right

2.9.3.2.3 Terminal 1 is designated as Ground.

2.9.3.2.4 Slip Ring conductors are wired to the inside of the terminals.

2.9.3.2.5 Torque terminal screws to 25-30 in -lbs.

Junction Box Terminal Locations
A = 1/12 Conductors
B = 13-24 Conductors
C = 25-36 Conductors

## 2.10 Spring Tension Adjustment

### 2.10.1 Spring Tension Warnings

2.10.1.1 More demanding applications may require spring tension adjustments for proper cable retraction.

2.10.1.2 **WARNING:** Do not allow cable to retract without restraining the retraction speed. Walk the cable back to the reel. The retraction speed should not exceed 150 ft/min. (approximately 1.7 mi/hr.).

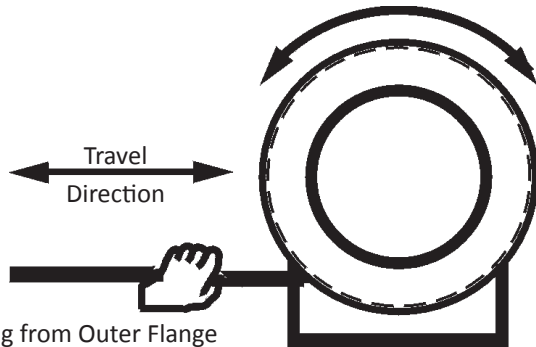

spool and cable together in the payout direction until the spring engages.

2.10.3.3 Single Spring Motors (L, E, F) and Parallel Spring Motors (LP, EP, FP) require two setup turns. Series Spring Motors (LS, ES, FS) require four (4) setup turns.

2.10.3.4 Next, feed the end of the cable through the roller guide (if present) and test the Spring Tension. Pull the cable out the required distance and allow it to rewind.

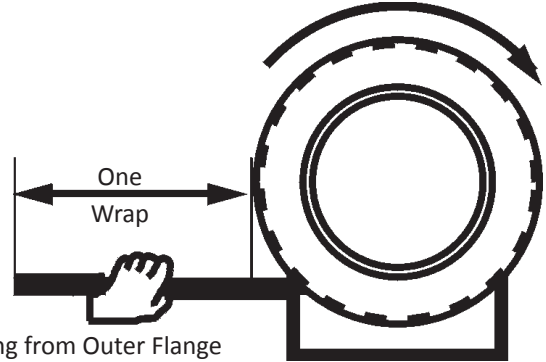

### 2.10.2 Spring Cycling

2.10.2.1 The spring should be cycled after mounting but before terminating the free end to assure that the cable will retract properly and operate under the correct tension.

2.10.2.2 This is accomplished by pulling the cable out the required distance and allowing it to rewind. This procedure should be performed five to ten (5-10) times.



### 2.10.4 Adjusting Spring Tension

2.10.4.1 One additional setup turn may be added to provide increased tension if the total number of spool revolutions required to fully retract the cable plus the setup turns is less than the maximum number listed in the table below. One (1) setup turn can be removed if the torque is too high.

2.10.4.2 Do not add or remove setup turns on the reel after the cable has been terminated. The resulting twist may kink the cable and shorten cable life.

2.10.4.3 Secure the end of the cable using the appropriate terminals.

### 2.10.3 Spring Pre-Tensioning

2.10.3.1 The proper pre-tensioning required for effective operation varies by cable diameter and cable weight. Trial and error is the most effective means of setting the proper spring pre-tension. Pre-tensioning is achieved by pre-loading the spring with setup turns (reel revolutions).

2.10.3.2 Relieve the spring of all tension before putting on setup turns. Grasp the end of the cable and the spool and rotate both

MAXIMUM SPRING TURNS	
Spring Motor	# Turns
E, EP, F, FP	15
L, LP	22
ES, FS	30
LS	44

## 3.0 Operation

3.1 Do not exceed the voltage or ampere rating of the cable. Do not exceed the voltage or ampere rating of the reel. Overheating, fire, damage to equipment or personal injury could result. Do not allow cable to retract without restraining the retraction speed.

3.2 Operate the reel within the cable size and length and Spring tensioning limits for which it was intended.

3.2.1 Two wraps of cable should remain on the reel at maximum extension to avoid excessive tension on the cable entrance watertight and slip ring terminations.

3.2.2 The spring should not be wound to the last two turns at maximum payout. This prevents over-stressing the spring(s), thus reducing its life or damaging the reel.

3.3 Keep the reel and cable clean to avoid excessive wear and damage.

3.4 Arrange for maintenance service if damage is found on the cable or reel.

3.5 To maximize spring life, cable should be fully retracted when not in use.

## 4.0 Maintenance

### 4.1 Maintenance Warnings

4.1.1 Be sure the power is off for maintenance.

4.1.2 Follow lock-out/tag-out procedures as outlined in OSHA Section 1910.147.

### 4.2 Lubrication

4.2.1 All springs and bearings are lubricated for life at the factory. Additional lubrication should not be required.

4.2.2 Do not apply any lubricants or solvent cleaning agents to the slip ring, brush, or insulator surfaces.

### 4.3 Inspections

4.3.1 Periodically check the reel for any loose or missing fasteners. Tighten or replace as necessary.

4.3.2 The slip ring assembly should be checked periodically as follows:

4.3.2.1 Clean to remove any accumulated dust or dirt from the slip ring housing area.

4.3.2.2 Check all brush and ring surfaces in the slip ring assembly and remove any accumulated dust.

4.3.2.3 Brushes should be centered on the slip rings and brush springs should be seated in the slot on top of the brush. Terminal screw connections should be tight.

4.3.2.4 Replace Brushes when the brush spring is within 0.09" of the ring insulator.

4.3.3 Inspect cable for damage or wear which would make it unsafe to use.

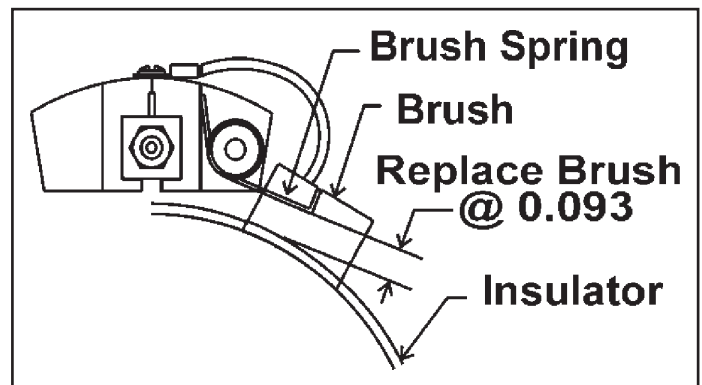

## 4.0 Maintenance

### 4.4 Spring Motor Replacement

4.4.1 Disconnect Power (as per Lock-Out/Tag-Out Procedures).

4.4.2 Some procedures may require mechanical assistance. The combined weight of the Cable, Spool, and Spring Motor may exceed 200 lbs.

4.4.3 Disconnect the terminated end of the cable. Wrap the cable onto the Reel Spool. Secure the cable on the spool using a zip-tie or similar fastener.

4.4.4 Make sure all spring tension is released and that the ratchet plate is free of the ratchet pawl.

4.4.5 Remove the Slip Ring Cover, Gasket, & Slip Ring as per Section 2.8, Slip Ring Replacement.

4.4.6 Remove any junction box, conduit connection or collar attached to the threaded end of the shaft.

4.4.7 Remove the service/feeder cable.

4.4.8 Remove the 1-1/2" Snap ring securing the Spool on the shaft.

4.4.5 Slip Ring Cover & Gasket

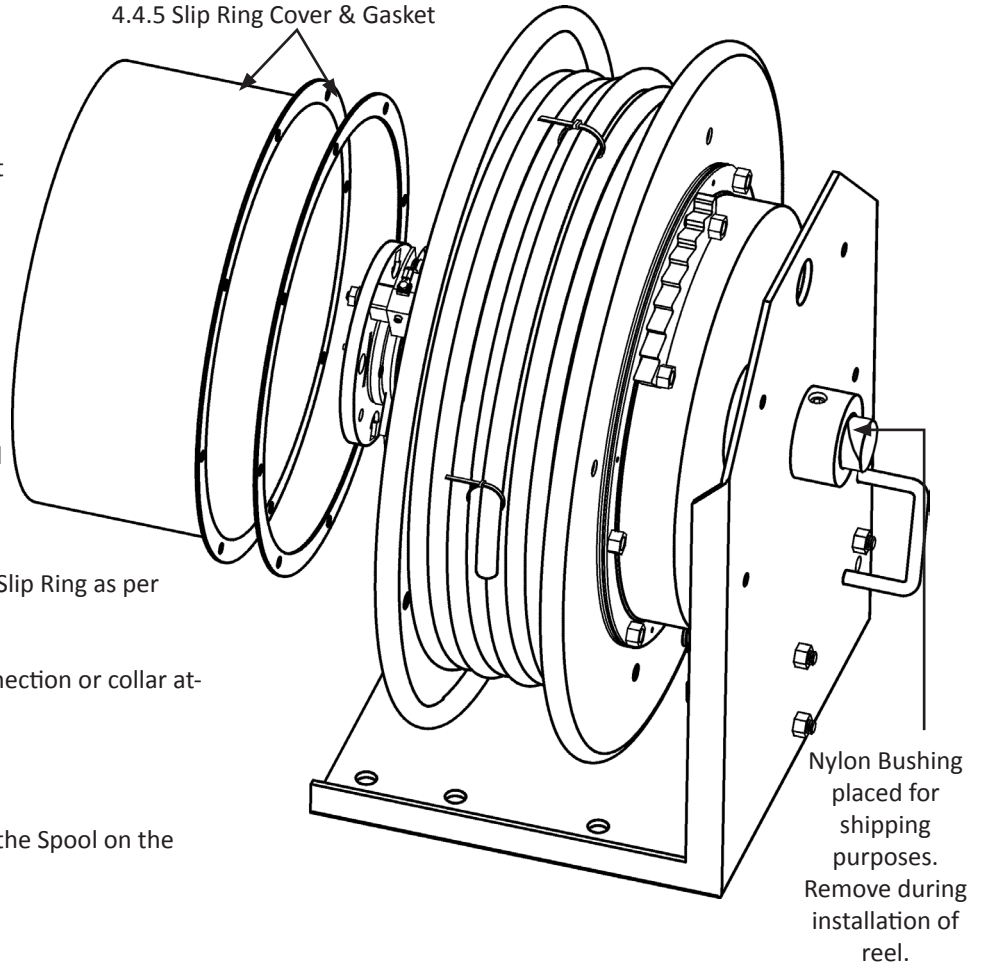

Nylon Bushing placed for shipping purposes. Remove during installation of reel.

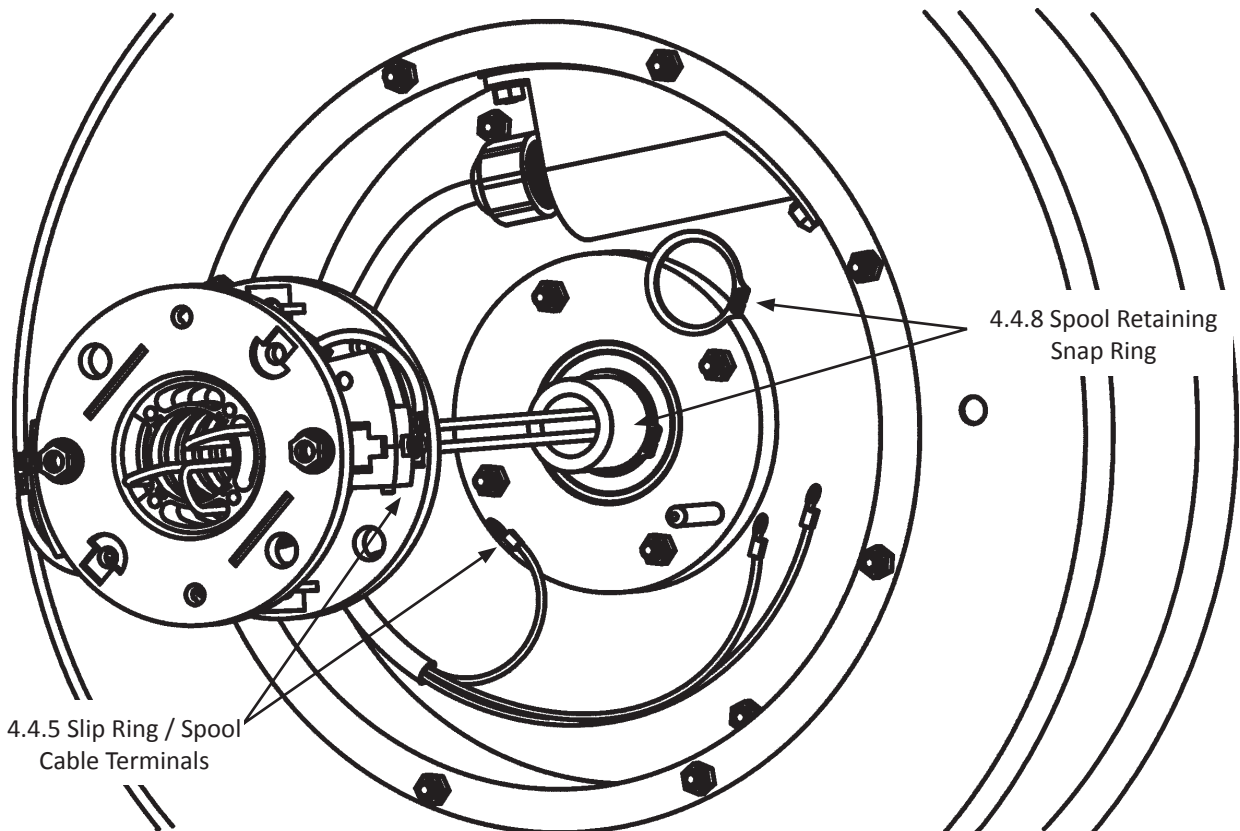

4.4.5 Slip Ring / Spool Cable Terminals

4.4.8 Spool Retaining Snap Ring

## 4.4 Spring Motor Replacement Continued

4.4.9 Loosen the 1/2-13 set screw in the Frame Hub using a 1/4 Hex (Allen) Wrench.

4.4.10 The Spool and Spring Motor Assembly are removed by sliding the shaft out of the frame assembly.

4.4.11 Lay the Spool down with the Spring Motor Shaft pointing up.

4.4.12 Remove the (8) 1/4-20 Keps Nuts that fasten the Spring Motor to the Spool. Remove the Ratchet Teeth, making note of their position(s) if present, and set aside.

4.4.13 Mount the new Spring Motor to the Spool.

4.4.14 Remount, making sure the hole in the shaft is aligned to the set screw hole in the frame hub. Torque the Spring Motor Nuts to 4 ft-lbs. Secure the 1/2-13 set screw in the Frame Hub to 28-35 ft-lbs using a 1/4 Hex (Allen) wrench.

4.4.15 Reverse steps 4.4.10 through 4.4.5 to reassemble.

4.4.16 Perform the Spring Tension Adjustment procedures outlined in Section 2.10.

4.4.17 Return the Reel to service.

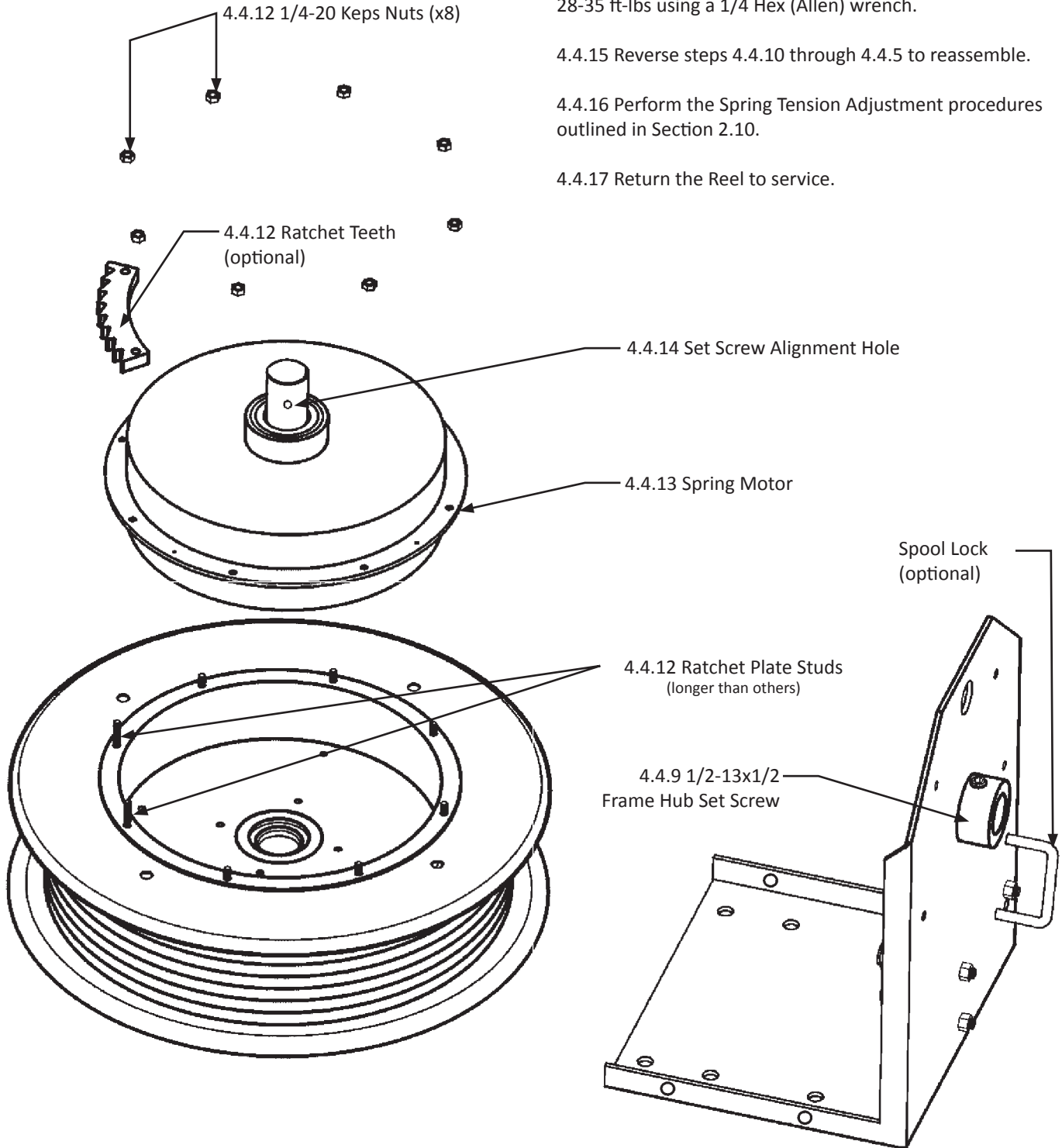

## 5.0 Troubleshooting

PROBLEM	POSSIBLE CAUSE	SOLUTION
Reel will not retract cable but has some tension.	<ol style="list-style-type: none"> <li>1) Improper pretension</li> <li>2) Incorrect reel for application (lift vs. stretch).</li> <li>3) Improper cable or cable length installed.</li> </ol>	<ol style="list-style-type: none"> <li>1) See Tension Adjustment section.</li> <li>2) Quantify application vs. reel selection.</li> <li>3) Install correct cable type and length.</li> </ol>
Reel does not have spring tension.	<ol style="list-style-type: none"> <li>1) Broken spring. *Quantify application to prevent reoccurrence.</li> </ol>	<ol style="list-style-type: none"> <li>1) Replace spring motor.</li> </ol>
Ratchet will not engage.	<ol style="list-style-type: none"> <li>1) Broken ratchet pawl spring.</li> </ol>	<ol style="list-style-type: none"> <li>1) Replace ratchet pawl spring.</li> </ol>
Ratchet will not disengage.	<ol style="list-style-type: none"> <li>1) Over-extension of reel.</li> </ol>	<ol style="list-style-type: none"> <li>1) Manually rotate reel spool to disengage ratchet. To prevent lockup, two wraps of cable should remain on spool at all times.</li> </ol>
Cable wraps improperly (uneven wrapping, wraps above or jumps flange).	<ol style="list-style-type: none"> <li>1) Reel mounting not level.</li> <li>2) Cable retraction rate too high.</li> <li>3) Cable guide out of adjustment.</li> </ol>	<ol style="list-style-type: none"> <li>1) Mount reel on level surface.</li> <li>2) Maintain steady retraction rate.</li> <li>3) Properly adjust cable guide.</li> </ol>
Cable twisting or knotting.	<ol style="list-style-type: none"> <li>1) Improperly installed cable.</li> <li>2) Cable rubbing on or bending around fixed object.</li> <li>3) Excessive spring tension.</li> <li>4) Inadequate anchoring of cable.</li> </ol>	<ol style="list-style-type: none"> <li>1) See Cable Install section in IOM.</li> <li>2) Check roller guide for function and cable pay out path.</li> <li>3) Quantify application vs. reel selection- and also check pretension.</li> <li>4) Adjust anchoring method. ie. add strain relief.</li> </ol>
Open or intermittent circuit.	<ol style="list-style-type: none"> <li>1) Inadequate connection.</li> <li>2) Brush loses contact with slip ring.</li> <li>3) Cable defective.</li> </ol>	<ol style="list-style-type: none"> <li>1) Check all termination points.</li> <li>2) Check brush wear, spring tension &amp; alignment.</li> <li>3) Perform continuity check on cable.</li> </ol>
Circuit trips and/or Pitted burned rings or brushes.	<ol style="list-style-type: none"> <li>1) Inadequate amp rating of reel.</li> </ol>	<ol style="list-style-type: none"> <li>1) Quantify application requirements vs. reel &amp; cable rating.</li> </ol>
Circuit arcing	<ol style="list-style-type: none"> <li>1) Amp or voltage above rating of reel.</li> <li>2) Excessive carbon dust accumulation.</li> <li>3) Water or moisture in slip ring.</li> </ol>	<ol style="list-style-type: none"> <li>1) Quantify application requirements vs. reel &amp; cable rating.</li> <li>2) Clean dust from inside slip ring.</li> <li>3) Check gasket seal.</li> <li>4) Replace brush spring.</li> </ol>