

REVISIONS			
REV.	DESCRIPTION	DATE	NAME
-	INITIAL RELEASE	8/1/2025	CG

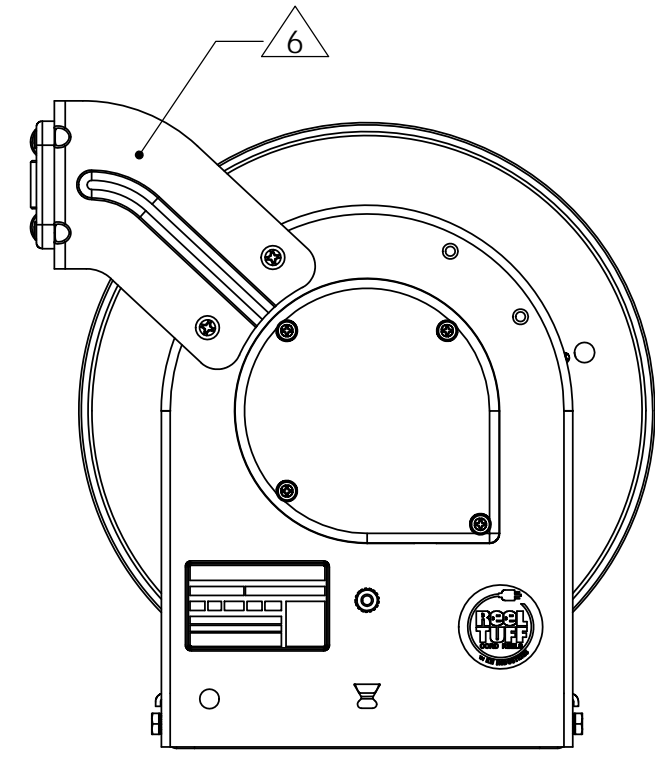

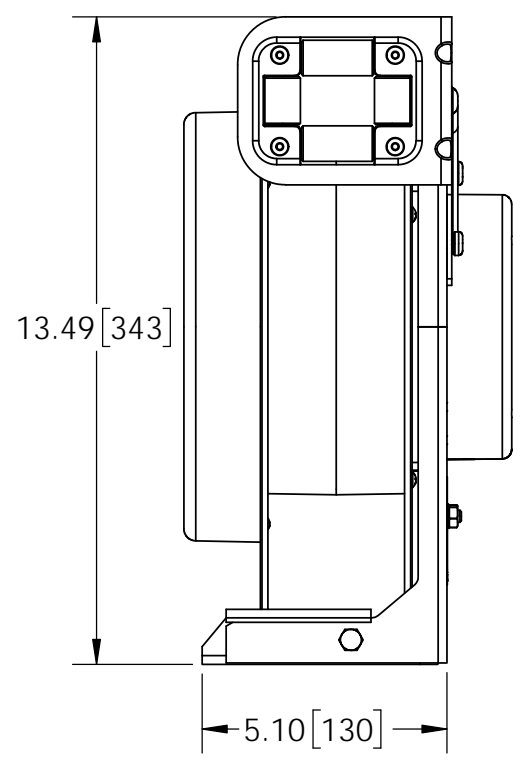

- NOTE:
1. INSTALLER'S RESPONSIBILITY TO CONSULT LOCAL MUNICIPALITY HAVING JURISDICTION FOR SPECIFICS ON MOUNTING AND ELECTRICAL GROUNDING REQUIREMENTS.
  2. ANCHORING/INSTALLATION HARDWARE NOT PROVIDED BY MANUFACTURER
  3. 125 VAC SLIP-RING
  4. NO GFCI PROTECTION OR SHORT CIRCUIT PROTECTION PROVIDED
  5. TO MAXIMIZE CORD LIFE DO NOT EXCEED DEPARTURE ANGLE WHEN EXTRACTING CORD
  6. GUIDE ARM HAS TWO MOUNTING POSITIONS
  7. SEPERATE MOUNTING PLATE
  8. NEMA-2 RATED FOR INDOOR USE
  9. 6' SUPPLY CORD (NOT SHOWN)
  10. ADJUSTABLE BALL STOP (NOT SHOWN)

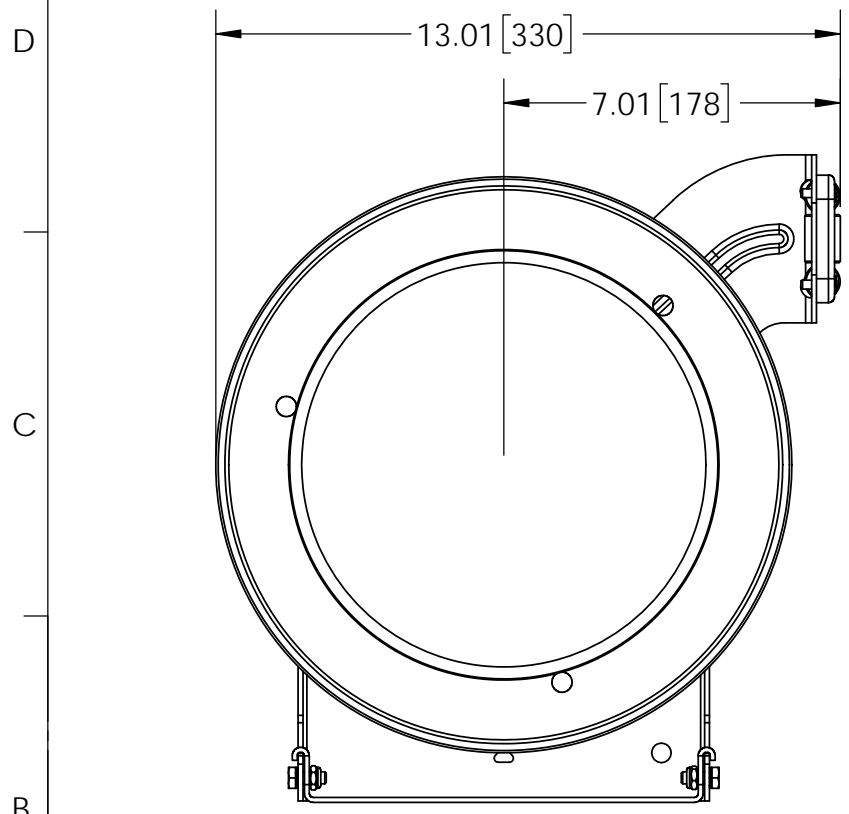
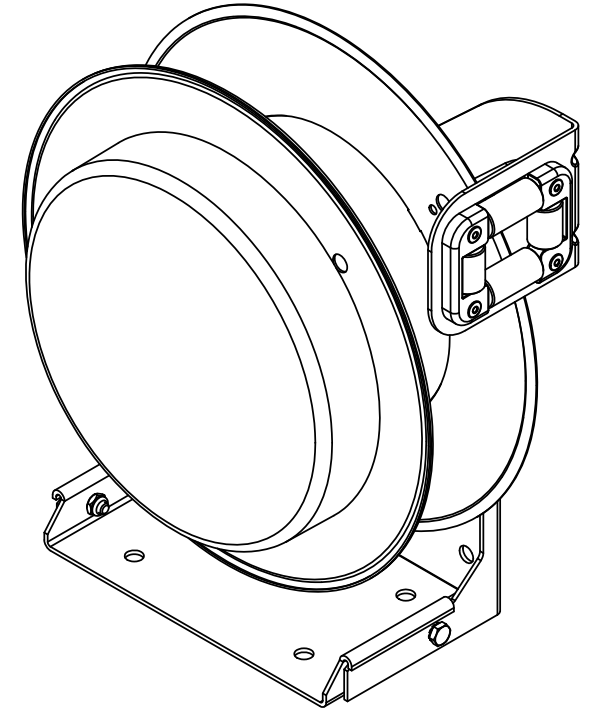
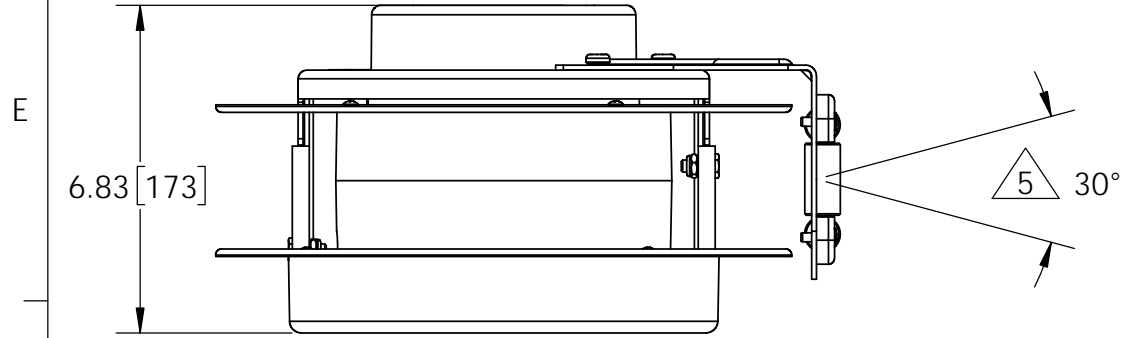
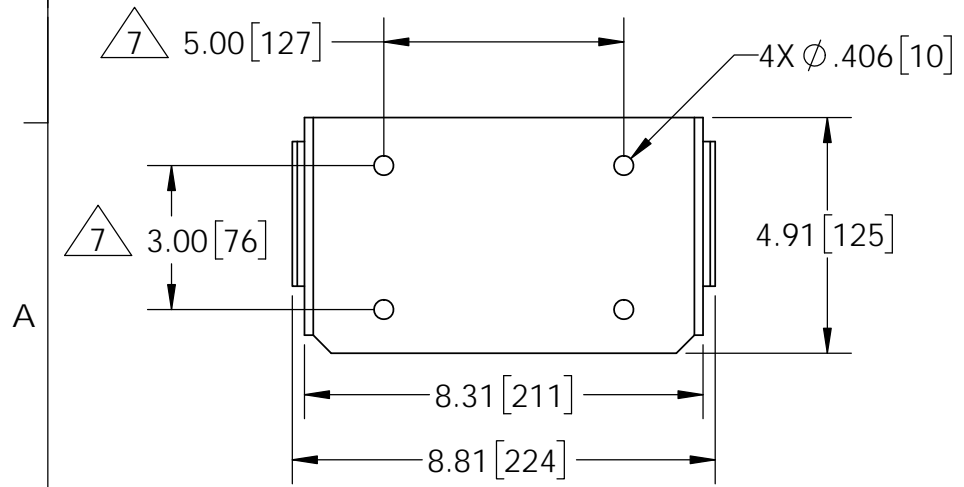

<b>PROPRIETARY AND CONFIDENTIAL</b> This drawing and the information shown constitute trade secret and confidential property of KH Industries Inc. It is subject to recall, and is loaned for use only in connection with the authorized manufacture or installation of KH Industries Inc. products, and on the condition that it will be treated as confidential and will not be disclosed, published or reproduced in whole or in part, or permitted to be viewed or used by any other party, without specific written permission. Receipt and use of the drawing and information constitutes acceptance and agreement to the above.	NAME	DATE	 <b>160 Elmview Ave. Hamburg, NY 14075 www.khindustries.com</b>	REV	
	DRAWN	CG			08/01/25
	CHECKED	RG			08/01/25
	APPROVED	RG	08/01/25	SIZE: DRAWING NUMBER: B RTA ASSEMBLY	-
UNLESS OTHERWISE SPECIFIED DIMENSIONS ARE IN INCHES			DESCRIPTION: RTA ASSEMBLY		
ANGULAR	.X ± 1°	.XX ± .1	.XXX ± .03	± .005	
 THIRD ANGLE PROJECTION			Material	Finish	
			SCALE: 1:4	DO NOT SCALE DRAWING	
			SHEET 1 OF 2		

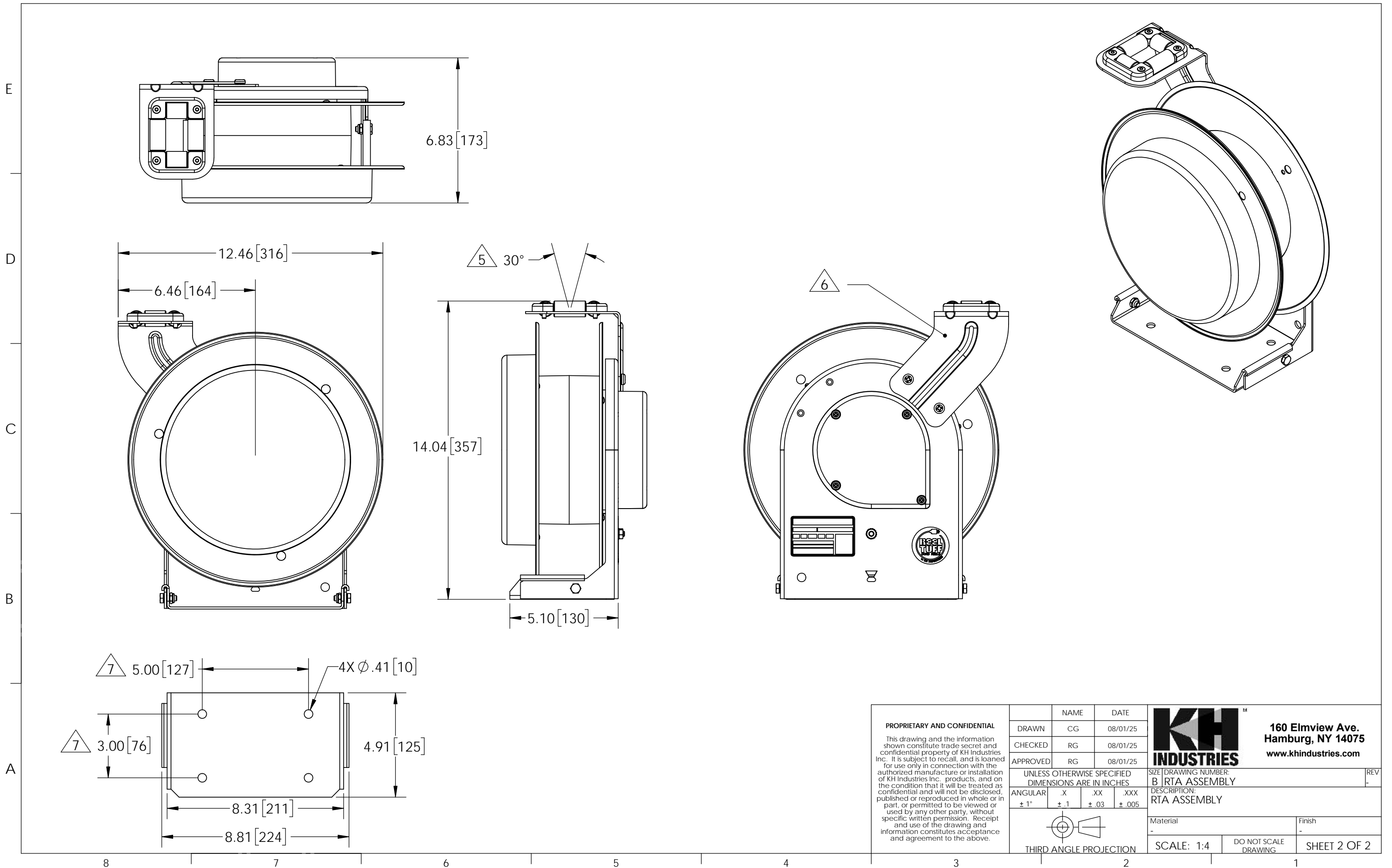
8 7 6 5 4 3 2 1

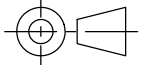

<b>PROPRIETARY AND CONFIDENTIAL</b> This drawing and the information shown constitute trade secret and confidential property of KH Industries Inc. It is subject to recall, and is loaned for use only in connection with the authorized manufacture or installation of KH Industries Inc. products, and on the condition that it will be treated as confidential and will not be disclosed, published or reproduced in whole or in part, or permitted to be viewed or used by any other party, without specific written permission. Receipt and use of the drawing and information constitutes acceptance and agreement to the above.		NAME	DATE	 <b>160 Elmview Ave.          Hamburg, NY 14075          www.khindustries.com</b>				
	DRAWN	CG	08/01/25					
	CHECKED	RG	08/01/25					
	APPROVED	RG	08/01/25	UNLESS OTHERWISE SPECIFIED DIMENSIONS ARE IN INCHES	SIZE: DRAWING NUMBER: B   RTA ASSEMBLY			
	ANGULAR	.X ± 1°	.XX ± .1	.XXX ± .03	.XXX ± .005	DESCRIPTION: RTA ASSEMBLY	REV	
	 THIRD ANGLE PROJECTION			Material: -	Finish: -	SCALE: 1:4	DO NOT SCALE DRAWING	SHEET 2 OF 2